



偉詮電子股份有限公司
Weltrend Semiconductor, Inc.

WT272C/WT274C

Dual/Quad Low Power CMOS OP Amplifiers

Data Sheet

REV. 1.12

October 16, 2009

The information in this document is subject to change without notice.
©Weltrend Semiconductor, Inc. All Rights Reserved.

新竹市科學工業園區工業東九路 24 號 2 樓
2F, No. 24, Industry E. 9th RD., Science-Based Industrial Park, Hsin-Chu, Taiwan
TEL:886-3-5780241 FAX:886-3-5794278.5770419



DESCRIPTION

The WT272C/WT274C is a dual/quad low power CMOS operational amplifiers IC. It provides high performance operation at low supply voltages. The basic amplifier can operate at supply voltage as low as 1.2V with very low power consumption and makes it perfect for battery-powered application. The input common-mode voltage extends to the negative rail. The output swings to both rails with light load. The input bias current is inherently low and the input impedance is extremely high. The devices are ideal upgrades for industrial standards OP amp.

FEATURES

- Low Power Replacement for Standard OP Amps
- Wide supply operating range (1.2V to 7V)
- Input common-mode voltage range includes negative rail
- Output swing to rail
- Low input bias current (typical 1pA)
- High input impedance
- Single supply operation
- Internal compensated
- Output short circuit protection

APPLICATIONS

- Portable Instruments
- Battery-Powered Systems
- Transducer Interfacing
- Active Filter
- High Impedance Buffer

ORDERING INFORMATION

Part Number	Package Type	Note
WT272C-N080 Pb	8-pin Plastic DIP, Lead-Free Package	There is a dot(●) on the right side of marking for lead-free package.
WT272C-S080 Pb	8-pin Plastic SOP, Lead-Free Package	
WT272C-NG080	8-pin Plastic DIP, Green Package	
WT272C-SG080	8-pin Plastic SOP, Green Package	
WT274C-N140 Pb	14-pin Plastic DIP, Lead-Free Package	There is a dot(●) on the right side of marking for lead-free package.
WT274C-S140 Pb	14-pin Plastic SOP, Lead-Free Package	
WT274C-NG140	14-pin Plastic DIP, Green Package	
WT274C-SG140	14-pin Plastic SOP, Green Package	

PIN CONFIGURATION

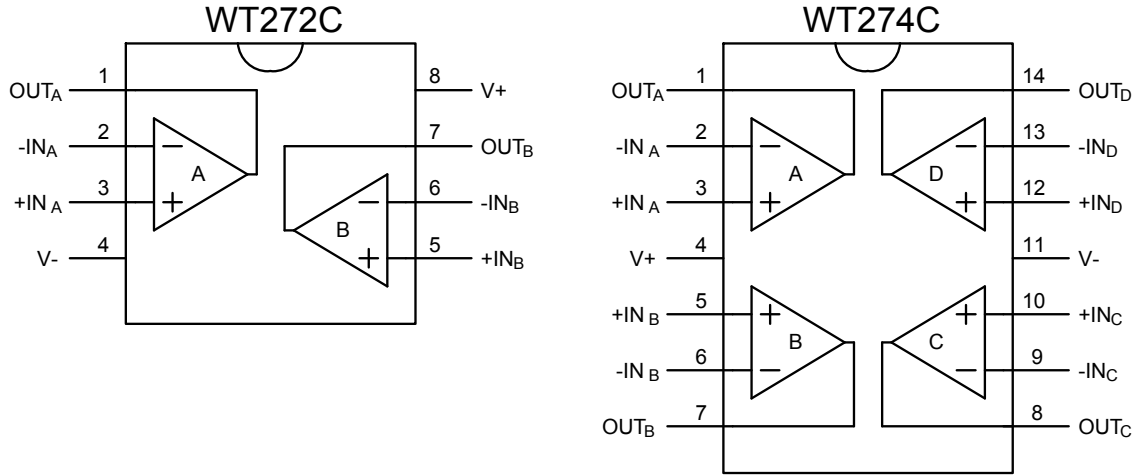

ABSOLUTE MAXIMUM RATINGS

Parameter	Min.	Max.	Units
DC supply voltage ($V_+ - V_-$)	0	8.5	V
Input and output voltage	$V_- - 0.3$	$V_+ + 0.3$	V
Storage temperature	-65	150	$^{\circ}C$
Ambient temperature with power applied	-20	100	$^{\circ}C$
Duration of output short circuit		Unlimited	

*Note: Stresses above those listed may cause permanent damage to the devices

RECOMMENDED OPERATING CONDITION

Symbol	Parameter	Condition	Min.	Typ.	Max.	Units
V_{SUPPLY}	Supply Voltage		1.2		7	V
I_{SOURCE}	Output Source Current				5	mA
I_{SINK}	Output Sink Current				9	μA
T_a	Ambient Temperature		0		85	$^{\circ}C$

ELECTRICAL CHARACTERISTICS

($V_+ = 5V$, $V_- = 0V$, $T_a = +25^{\circ}C$ unless otherwise specified)

Symbol	Parameter	Condition	Min.	Typ.	Max.	Units
V_{OS}	Input Offset Voltage			2	5	mV
$\Delta V_{OS}/\Delta T$	Average Temperature Coefficient of Input Offset Voltage			0.7		$\mu V/^{\circ}C$
I_{OS}	Input Offset Current			1		pA
I_{BIAS}	Input Bias Current	$T_a = 25^{\circ}C$		1		pA
V_{ICOM}	Input Common Mode Voltage		0		$V_+ - 1.3$	V
V_{OUT}	Output Voltage Swing	$V_{in} = 10mV$ $R_L = 1M\Omega$ connected to V_-	4.9	4.99		V



WT272C/WT274C

Data Sheet Rev. 1.12

		V _{in} =10mV R _L =100KΩ connected to V-		4.95		V
		V _{in} =10mV R _L =10KΩ connected to V-		4.75		V
		V _{in} = -10mV R _L =1MΩ, connected to V+		0.5	0.7	V
		V _{in} = -10mV R _L =100KΩ connected to V+		0.65		V
A _{VOL}	Large Signal Voltage Gain	V _O = 1V to 4V, V _i =1.4V R _L =1MΩ	20	100		V/mV
GBW	Unit Gain Bandwidth	R _L =1MΩ, C _L =50pF		0.1		MHz
CMRR	Common Mode Rejection Ratio	V _O = 1V, V _i =0 to 3.5V	60	80		dB
PSRR	Power Supply Rejection Ratio	V _O = 1V	60	90		dB
SR	Slew Rate	A _{VOL} =1, C _L =100pF V _{IN} =5V _{P-P}		0.03		V/μs
I _{SUPPLY}	Supply Current (per amplifier)			5	9	μA
φ _m	Phase Margin at Unit Gain	R _L =1MΩ, C _L =50pF		55		Degree
e _n	Input Equivalent Noise Voltage	f=1KHz, R _s =100Ω		50		nV/√Hz
V _{O1} /V _{O2}	Channel Separation	A _{VOL} =100		120		dB

TYPICAL APPLICATION CIRCUIT

Voltage Follower

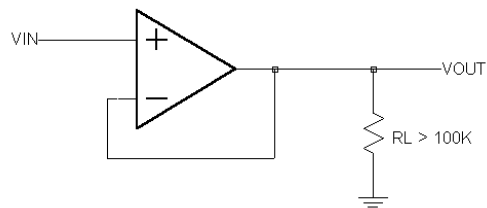

Instrument Amplifier

